

MIDI

Compact Power Unit

MIDI SERIES

STANDARD UNIT WITH GEAR PUMP, STUDIED TO OPTIMIZE THE HYDRAULIC CIRCUIT.

THE MIDI UNIT DESCEND FROM "MINI" TECHNOLOGY.

**SAVE TIME ON TANK MACHINING WITH JUST ONE HOLE TO FIX ELECTRIC MOTOR, PUMP,
AND INITIAL VALVE/S BLOCK**

CHARACTERISTICS:

- COMPACT
- REDUCED DIMENSIONS AND WEIGHTS
- GEAR PUMPS 4-31 c.c./REV
- MAX PRESSURE UP TO 250 BAR
- ELECTRIC MOTORS 2.2-9 kW

COMPOSITION:

- COUPLING
- GEAR PUMP
- CHARGE PLUG
- DISCHARGE PLUG
- FILTER
- MANIFOLD NG6 AND NG10

OPTIONALS:

- OIL HEATER
- THERMOSTAT
- WATER/OIL EXCHANGER
- AIR/OIL EXCHANGER
- ACCUMULATOR
- ELECTRIC OIL LEVEL

MANIFOLDS:

- ACCESSORIES:
- RELIEF VALVE
 - RETURN LINE FILTER
 - PRESSURE GAUGE

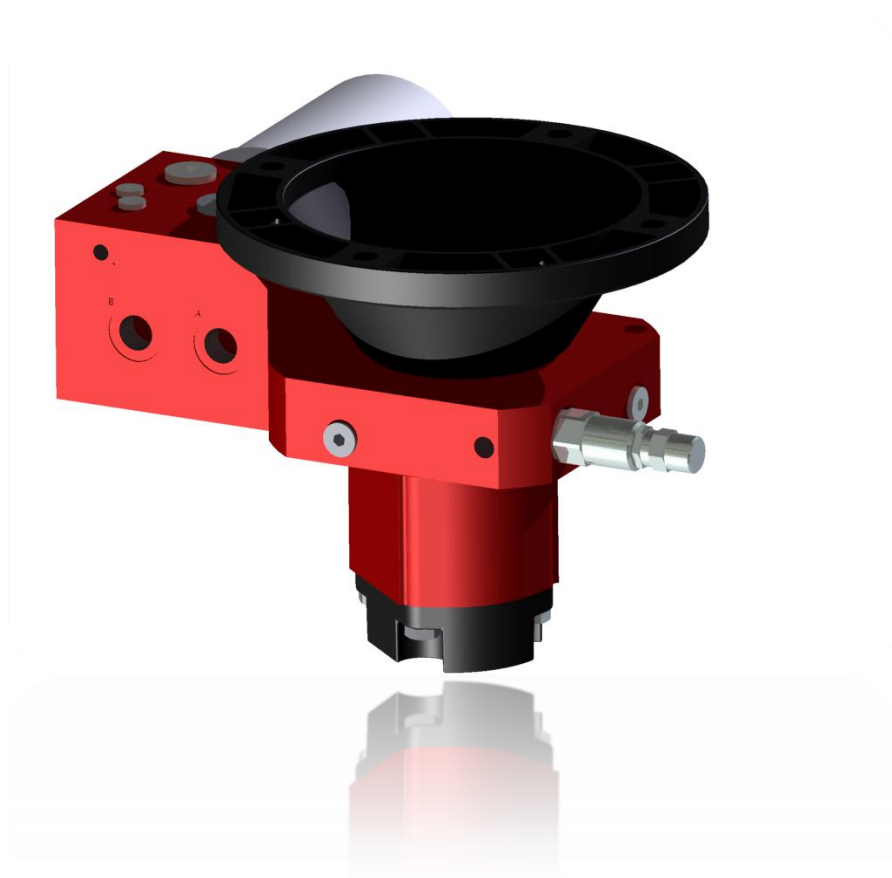

PERFORMANCE CHART

	31 cc/rev	25 cc/rev	20 cc/rev	17 cc/rev	14 cc/rev	11 cc/rev	8 cc/rev	6 cc/rev	4 cc/rev
2.2 Kw	47lt 30bar	37lt 40bar	29lt 45bar	24.5lt 50bar	20lt 60bar	16lt 75bar	12lt 100bar	8.5lt 140bar	6lt 209bar
3 Kw	47lt 45bar	37lt 50bar	29lt 60bar	24.5lt 70bar	20lt 80bar	16lt 105bar	12lt 135bar	8.5lt 190bar	6lt 250bar
4 Kw	47lt 60bar	37lt 70bar	29lt 80bar	24.5lt 95bar	20lt 110bar	16lt 140bar	12lt 180bar	8.5lt 250bar	
5.5 Kw	47lt 80bar	37lt 95bar	29lt 110bar	24.5lt 130bar	20lt 150bar	16lt 190bar	12lt 245bar		
7.5 Kw	47lt 110bar	37lt 130bar	29lt 145bar	24.5lt 175bar	20lt 200bar	16lt 240bar			
9 Kw	47lt 135bar	37lt 150bar	29lt 175bar	24.5lt 210bar	20lt 245bar				

MANIFOLD NG6

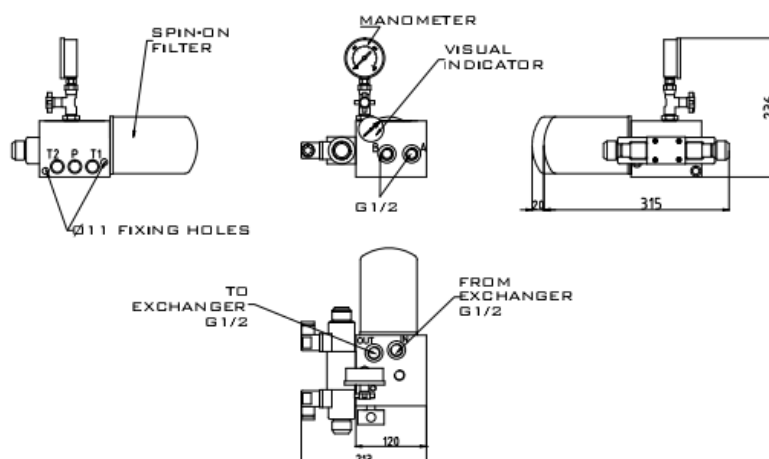

MANIFOLD NG10

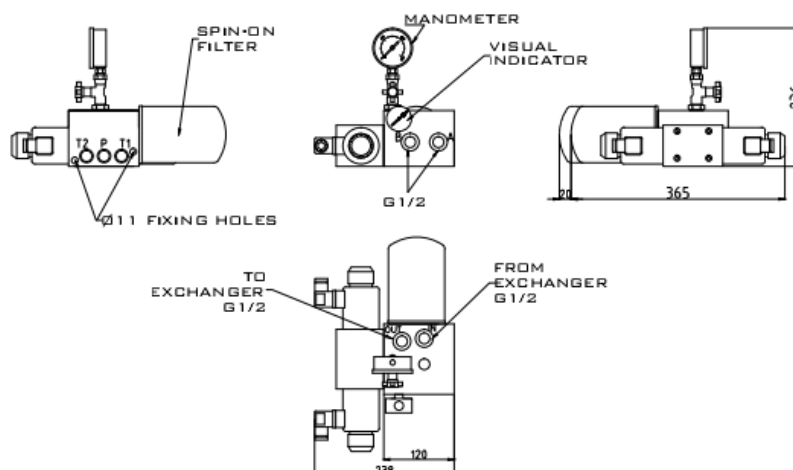

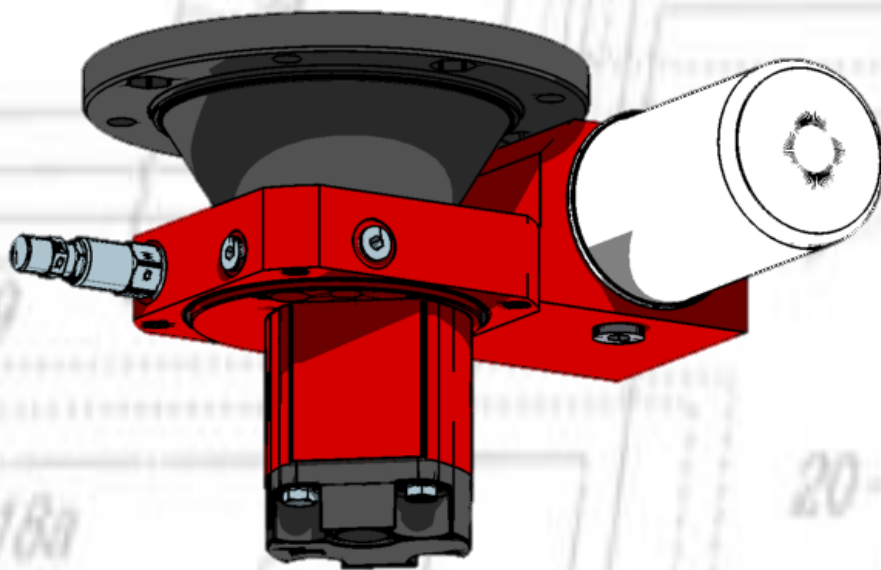

www.rbhydraulics.eu

RB Hydraulics S.r.l.
Via Kennedy, 13/15
20100 Boffalora Ticino (MI)
Tel/Fax +39 02 97250475
info@rbhydraulics.eu - www.rbhydraulics.eu