

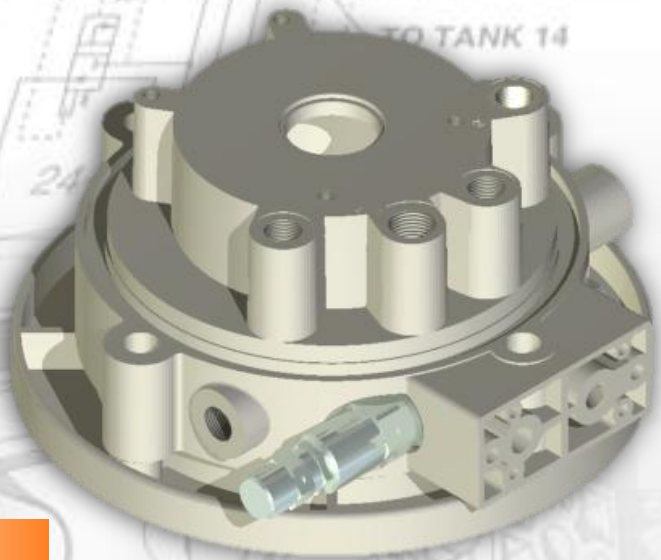

A NEW WAY TO BUILT UP POWER UNITS

Reduced : *assembling time*
stock inventory
overall dimensions



BHB

BELL-HOUSING BLOCK

SAVE ASSEMBLING TIME

Greatly reduced pipe work.

Save time on tank machining with just one hole to fix electric motor, pump, and the initial valve/s block.

REDUCED STOCK INVENTORY

Thanks to two additional adaptors only one basic bell-housing covers electric motor power from 0.75 up to 9Kw

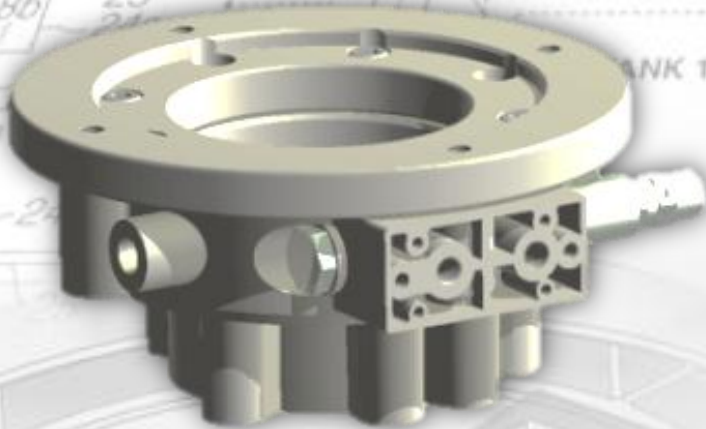

CREATE YOUR OWN CIRCUIT

Thanks to the wide range of final blocks available you can create many different types of circuiteries

REDUCED OVERALL DIMENSION

All the basic components of a power unit in just one block.

This way you save weight, space and make it easier to assemble